

12CS Series

Coreless Spin-on Filter

Max. 75 l/min - 35 bar



Environmentally friendly alternative for spin-on filtration

Lightweight, non-metallic element that can be incinerated

The 12CS Series features a Parker, replaceable coreless Ecoglass III element in a re-usable bowl for easy used element removal and disposal. Maximum pressure 35 bar and the Ecoglass element offers a low environmental impact in landfills.



Contact Information:

Parker Hannifin
Hydraulic Filter Division Europe

European Product Information Centre
Freephone: 00800 27 27 5374
(from AT, BE, CH, CZ, DE, EE, ES, FI, FR, IE, IT, PT, SE, SK, UK)
filtrationinfo@parker.com

www.parker.com/hfde

Product Features:

- 12CS features a Parker quality, replaceable coreless Ecoglass III element.
- Re-usable bowl design for easy element removal.
- Maximum pressure 35 bar.
- An eco filter solution for hydraulic systems.

Coreless Spin-on Filters

12CS Series

WASTE.



500,000,000+

spin-on cans disposed
of each year in North
American landfills.

30,000,000

gallons of discarded
residual waste oil.

250,000

tons of scrap metal.
Expensive disposal costs.

NOT.



The Smart Alternative to Spin-on Cans!

Features:

Parker engineers have developed an innovative alternative to the age old spin-on style can. This new design provides all of the benefits of high efficiency, long life Ecoglass III filtration, without the environmental impact.

The new environmentally-friendly 12CS hydraulic filters feature a reuseable bowl and a quality filter element constructed primarily of nylon and fiberglass. The element core is permanently attached as part of the filter bowl. When replaced, the element reduces costs, eliminates hot drain requirements, can be easily incinerated, and is better-suited for most landfills.

The 35 bar filter is rated up to 220 l/min, with premium Ecoglass III elements as standard offerings. The element design also prevents filter operation if the proper element is not in place.

Applications:

- Mobile Ag
- Mobile Construction
- Material Handlers
- Aerial Lifts
- Pilot lines
- Charge pump hydrostatic drives
- Industrial power units
- Machine tools

Feature	Advantage	Benefit
<ul style="list-style-type: none"> 35 bar operating pressure 	<ul style="list-style-type: none"> Withstands pressure surges, allows application versatility. 	<ul style="list-style-type: none"> Broader applications compared to lower rated spin-on cans.
<ul style="list-style-type: none"> Parker quality element 	<ul style="list-style-type: none"> Provides head-to-bowl seal. Must be installed for operation. Ensures original element must be used. 	<ul style="list-style-type: none"> Provides optimum leak-free performance. Meets system cleanliness requirements.
<ul style="list-style-type: none"> Coreless Ecoglass elements 	<ul style="list-style-type: none"> Lightweight, non-metallic. Ease of service and disposal. 	<ul style="list-style-type: none"> Reduces disposal costs. Can be incinerated. Low environmental impact in landfills.
<ul style="list-style-type: none"> Spin-on filter assembly w/re-usable bowl 	<ul style="list-style-type: none"> Improved, cost-effective design. 	<ul style="list-style-type: none"> Easy to maintain.

Specifications

Pressure Ratings:

Maximum Allowable
Operating Pressure (MAOP):
35 bar (500 psi)
Fatigue: 27.6 bar (400 psi)
1,000,000 cycles: 27.6 bar
Design Safety Factor: 2.5:1

Operating Temperatures:

Buna: -40°C to 107°C

Element Collapse Rating:

10.3 bar (150 psid)

Element Condition Indicators:

For predictive maintenance, 3 types of indicator are available: An electrical analogue or switch type indicator or a battery operated visual LED indicator.

Materials:

Head: die cast aluminium
Bypass valve: nylon with steel spring
Filter element: fibreglass and polyester
with nylon endcaps

Bowl: steel
Permanent core: steel

Weights (approximate):

12CS-2..... 1.4 kg (3lbs.)

12CS-2

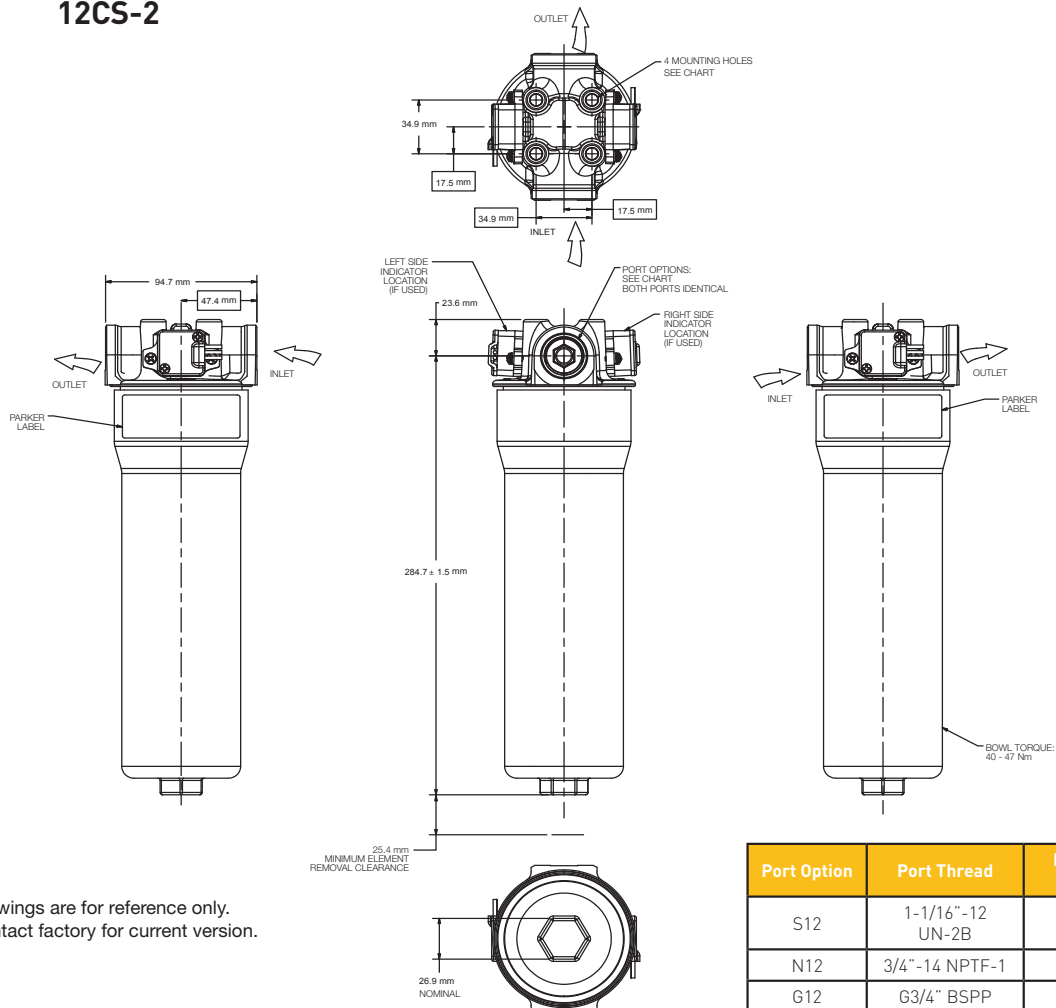

Drawings are for reference only.
Contact factory for current version.

Port Option	Port Thread	Mounting Thread Configuration
S12	1-1/16"-12 UN-2B	3/8" x 16 x 5/8"
N12	3/4"-14 NPTF-1	3/8" x 16 x 5/8"
G12	G3/4" BSPP	3/8" x 16 x 5/8"

Coreless Spin-on Filters

12CS Series

12CS-2 Performance

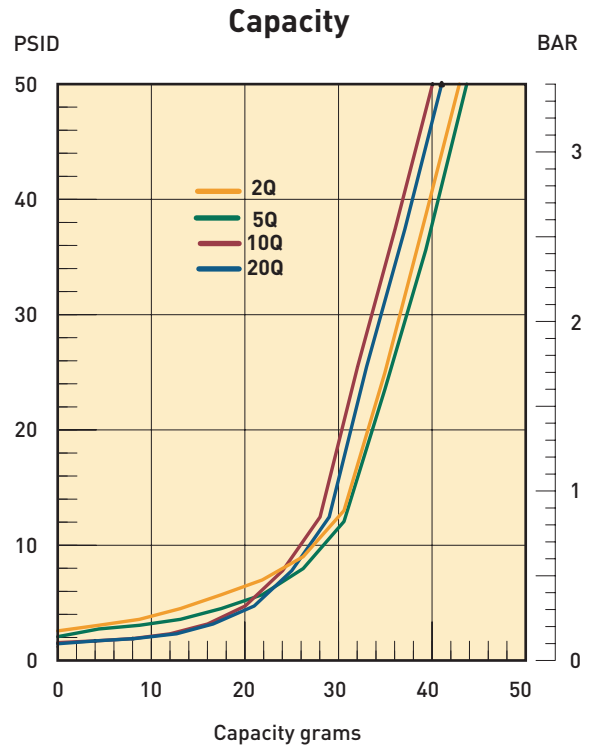
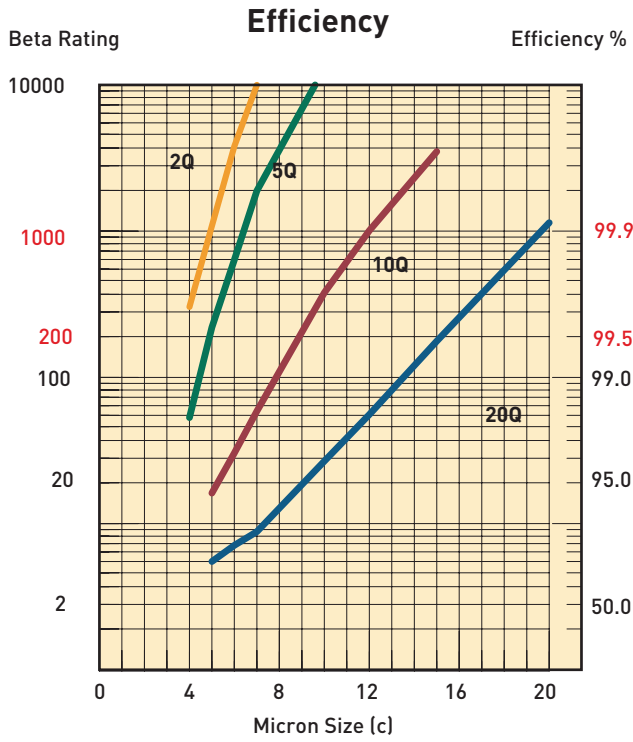

Results typical from Multi-pass tests run per test standard ISO 16889 @ 15 gpm to 50 psid terminal - 10 mg/L BUGL
Refer to Appendix for relationship to test standard ISO 4572.

Flow vs Pressure Loss

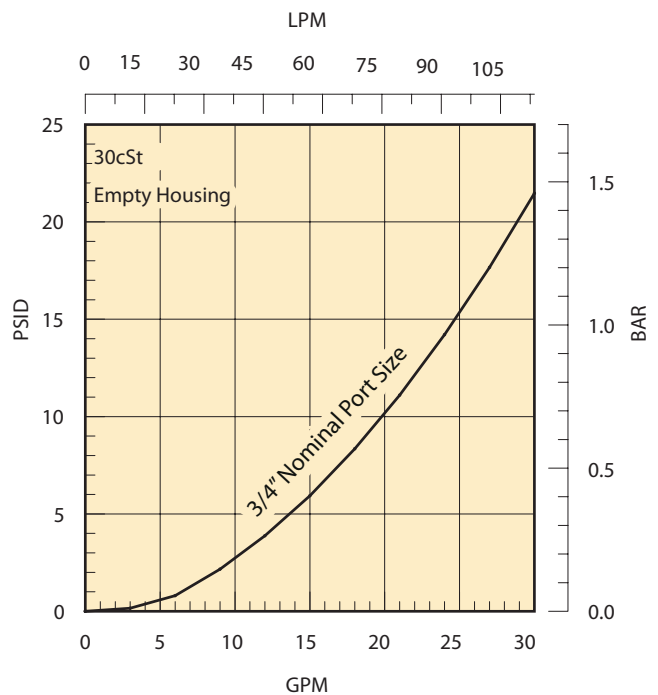
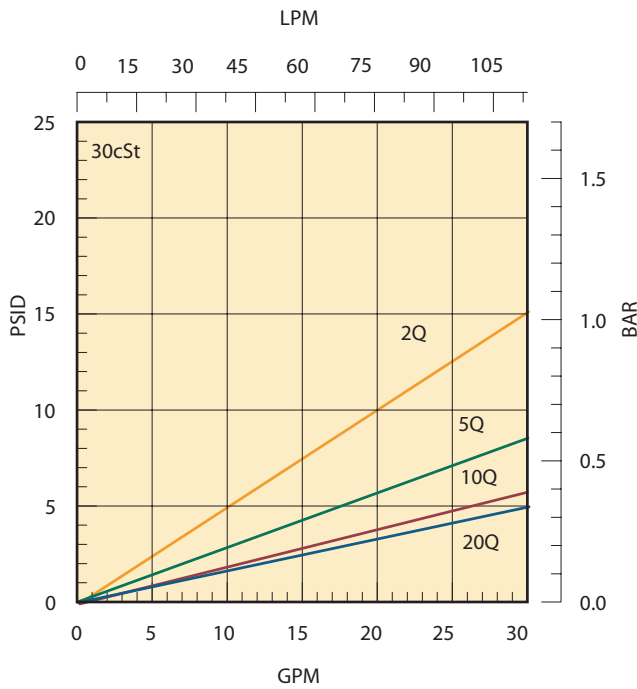

Coreless Spin-on Filters

12CS Series

Service Instructions 12CS

Filter Service

Filter element should be replaced as indicated by filter indicator gauge, or at specified service intervals recommended by the OEM.

Replacement element procedure

- Shut down system and release pressure in the filter line.
- Loosen bowl and remove rotating counter clockwise.
- Remove dirty element from filter head and discard.
- Lubricate element seals on clean element and install on filter head element locator.
- Install reusable bowl onto element and filter head.



Parts List

Index		12CS
1	Head	
	SAE-12	942249
	3/4" NPT	942250
	G3/4" BSPP	942251
2	Bypass	
	3.5 bar assembly	928981
3	Element	
	02QE	940765Q
	05QE	940764Q
	10QE	940763Q
	20QE	940762Q
4	Bowl	
	Double	937599
	Indicators	
5	Analogue Electrical	941802
6	Reed switch (on-off)	941814
7	Visual Red-LED	941945

Element Condition Indicators

- Analog Electrical**
 - Supply voltage: 4.5 to 5.5 VDC
 - Main output current: 1 mA
 - Output voltage: Ratiometric (see graph)
 - Approvals: CE, IP68
 - Connector: 12" wire leads, 18 Gauge
 - Yellow (analog out)
 - Black (0V)
 - Red (supply +5 V)

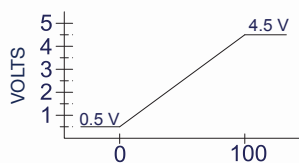

ELEMENT LOAD CONDITION (% LOADED)

- Electrical Switch (Reed switch - On/Off)**
 - Connector: 12" wire leads, 18 Gauge
 - Yellow (NC), black (NO), Red (C)
 - Maximum switching voltage: 30V (DC/AC)
 - Maximum switching current 0.2A
 - Maximum carry current: 0.5A
 - Approvals: CE, IP68
- Visual Indicator (Red - LED)**
 - Push to test
 - Battery operated
 - Visual LED (red = change element)



Electrical Switch or Analog Sensor



Visual Indicator

Coreless Spin-on Filters

12CS Series

How To Order

Select the desired symbol (in the correct position) to construct a model code.

Example:

BOX 1	BOX 2	BOX 3	BOX 4	BOX 5	BOX 6	BOX 7	BOX 8
12CS	2	10QE	B	P	G	S12	1

BOX 1: Basic Assembly	
Symbol	Description
12CS	Coreless Spin-On, 75 l/min nominal

BOX 6: Bypass	
Symbol	Description
K	3.5 bar (50 PSID)

BOX 2: Length	
Symbol	Description
2	Double

BOX 7: Ports	
Symbol	Description
S12	SAE-12 integral threads*
N12	3/4" NPT integral threads
G12	G3/4" BSPP (ISO 220) integral threads

*Porting recommended for best delivery.

BOX 3: Element Media	
Symbol	Description
02QE	Ecoglass III, 2µm
05QE	Ecoglass III, 5µm
10QE	Ecoglass III, 10µm
20QE	Ecoglass III, 20µm

BOX 8: Option	
Symbol	Description
1	No options

BOX 4: Seals	
Symbol	Description
B	Nitrile (NBR)
Consult Parker for additional seal options	

BOX 5: Indicator	
Symbol	Description
N	None

Replacement Elements (Ecoglass)

Media	Filter Model - Nitrile seals
	12CS-2
02QE	940765Q
05QE	940764Q
10QE	940763Q
20QE	940762Q